

INSTALLING THE SPEED REDUCER ON THE GN1324 & GN1340

The speed reduction unit for the Granite machines consists of an intermediate pulley that is positioned between the motor and the spindle pulley. This setup produces a top speed of 400 RPM and greatly increases the torque available at the slower speeds. This also dramatically reduces the load on the motor and all electronic components.

The kit comes with the pulley, shaft, mounting bracket, and a modified support spacer for the gear quadrant and new belts. **MAKE SURE THE MACHINE IS UNPLUGGED BEFORE STARTING MAINTENANCE OR MODIFICATIONS!**

Refer to page 104 of the owner's manual for a diagram of the gear quadrant. Item 20 in the diagram will need to be replaced.

1. Remove the bolt (15) holding the gear quadrant (18) in place and pull out the spacer (20).

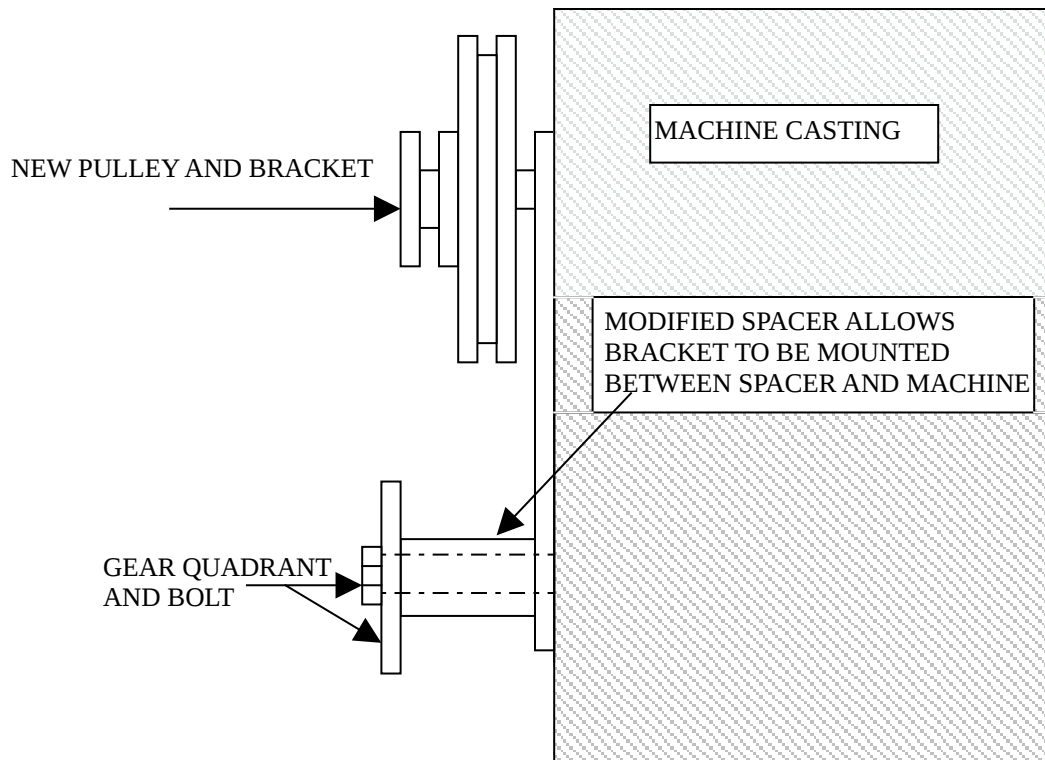

2. Reassemble the quadrant with the modified spacer and the new bracket mounted against the machine as shown above.

NOTE: There may be a screw on some machines that is located where the new bracket would hit on the screw head. This screw can be removed and discarded. Its original purpose was to help hold the sheet metal of the box in place, but there are several of these in the box and one will not be missed.

3.The belt arrangement for the speed reducer is as shown below

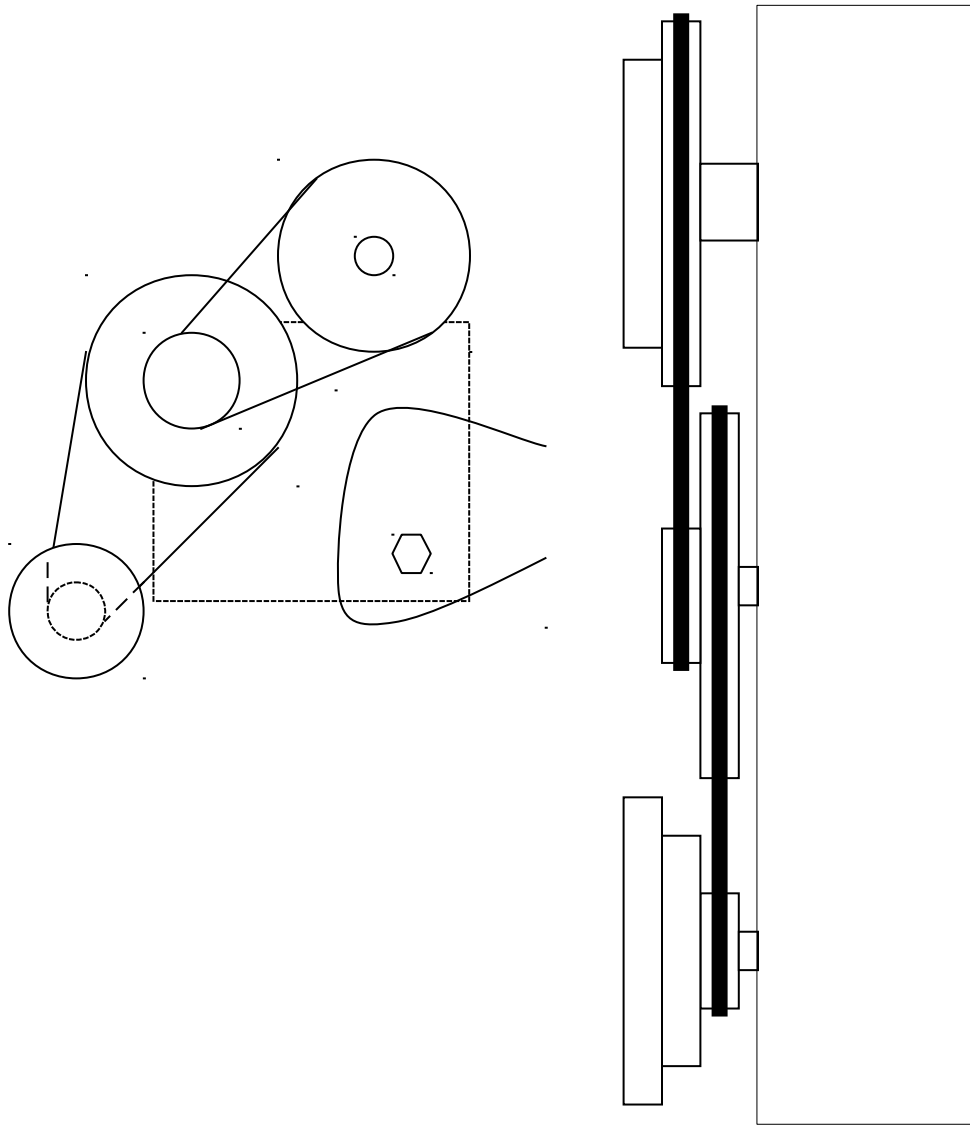

4.To go back to the faster speeds, remove the two belts and reinstall the single belt. The single belt may ride on one side of the speed reducer pulley and make it turn also. This is normal and will not cause any problems.